

WEDGE GATE VALVES

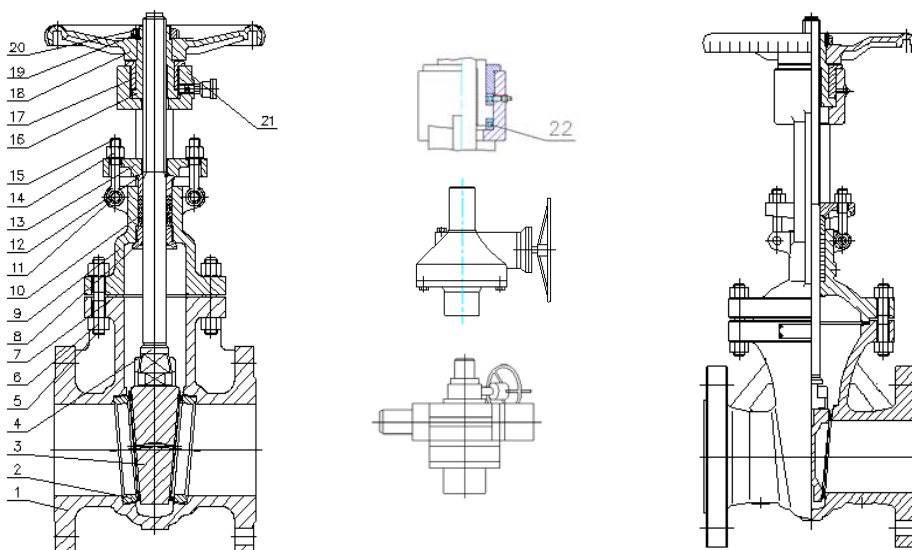

Material Specifications

NO.	Parts	Materials					
		Standard	Low Temperature		High Temperature		
1	Body	A216 WCB	A352 LCB	A352 LC2	A217 WC6	A217 WC9	A217 C5
2	Seat	A105①	A182 F304①	A182 F304①	A182 F11①	A182 F22①	A182 F5a①
3	Wedge Gate	A216 WCB①	A352 LCB①	A352 LC2①	A217 WC6①	A217 WC6①	A217 C5①
4	Stem	A276 410	A276 304	A276 304	A276 410	A276 410	A276 410
5	Bonnet Bolt	A193 B7	A320 L7	A320 L7	A193 B16	A193 B16	A193 B16
6	Bonnet Nut	A194 2H	A194 4	A194 4	A194 4	A194 4	A194 4
7	Gasket	Graphite+304	Graphite+304	Graphite+304	Graphite+304	Graphite+304	Graphite+304
8	Backseat	A276 410	A276 304	A276 304	A276 410	A276 410	A276 410
9	Bonnet	A216 WCB	A352 LCB	A352 LC2	A217 WC6	A217 WC9	A217 C5
10	Packing	Graphite+304	Graphite+304	Graphite+304	Graphite+304	Graphite+304	Graphite+304
11	Eyebolt Pin	ASTM A29	ASTM A29	ASTM A29	ASTM A29	ASTM A29	ASTM A29
12	Gland	A276 410	A276 304	A276 304	A276 410	A276 410	A276 410
13	Gland Flange	CS	CS	CS	CS	CS	CS
14	Gland Nut	A194 2H	A194 4	A194 4	A194 4	A194 4	A194 4
15	Gland Bolt	A193 B7	A320 L7	A320 L7	A193 B16	A193 B16	A193 B16
16	Stem Nut	Bronze / A439 D2	Bronze / A439 D2	Bronze / A439 D2	Bronze / A439 D2	Bronze / A439 D2	Bronze / A439 D2
17	Stem Nut Retainer	ASTM A29	ASTM A29	ASTM A29	ASTM A29	ASTM A29	ASTM A29
18	Handwheel	Cast Iron	Cast Iron	Cast Iron	Cast Iron	Cast Iron	Cast Iron
19	Set Screw	CS	CS	CS	CS	CS	CS
20	Handwheel Nut	ASTM A29	ASTM A29	ASTM A29	ASTM A29	ASTM A29	ASTM A29
21	Yoke	A216 WCB	A352 LCB	A352 LC2	A217 WC6	A217 WC9	A217 C5
22	Bearing	Assembly	Assembly	Assembly	Assembly	Assembly	Assembly

Note: ① Seal surface materials can be designed according to customer's requirement.

ANSI WEDGE GATE VALVES

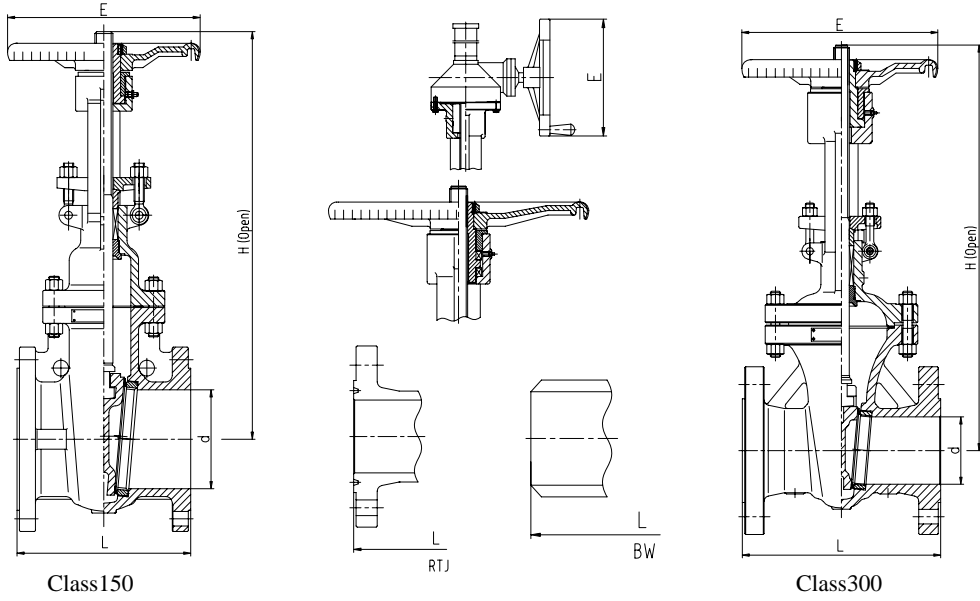

Class150 , NPS \geq 14" and Class300 , NPS \geq 12" With bearing , yoke and bonnet are bolted.

Class150, NPS \geq 26" and Class300, NPS \geq 18" With gear operation,
Class150, 8" \leq NPS \leq 24" and Class300, 8" \leq NPS \leq 16" Customer can choose gear operation or not.

Dimensions and Weights (Class150~Class300)

Class		150																	
NPS(in)		2	2 1/2	3	4	5	6	8	10	12	14	16	18	20	24	28	30	36	
Dimensions(mm)	d	51	64	76	102	127	152	203	254	305	337	387	438	489	591	686	737	876	
	L	RF	178	190	203	229	254	267	292	330	356	381	406	432	457	508	610	610	711
		BW	216	241	283	305	381	403	419	457	502	572	610	660	711	813	914	914	1016
		RTJ	191	203	216	241	267	279	305	343	368	394	419	445	470	521	—	—	—
	H	387	435	481	585	681	765	956	1149	1351	1508	1703	1892	2119	2500	2960	3148	3721	
E	200	200	250	280	280	300	350	400	450	500	550	600	600	650	610	610	610	610	
Weights(kg)	RF	18	25	32	50	64	77	121	178	265	362	463	621	792	1190	1838	2261	3310	
	BW	15	18	26	41	58	69	108	156	248	330	424	587	752	1144	1900	3310	3380	
Class		300																	
NPS(in)		2	2 1/2	3	4	5	6	8	10	12	14	16	18	20	24	26	28	30	
Dimensions(mm)	d	51	64	76	102	127	152	203	254	305	337	387	438	489	591	635	686	737	
	L	RF/BW	216	241	282	305	381	403	419	457	502	762	838	914	991	1143	1245	1346	1397
		RTJ	232	257	298	321	397	419	435	473	518	778	854	930	1010	1165	1270	1372	1422
	H	410	453	509	612	670	805	1000	1209	1416	1582	1725	1959	2194	2598	2986	3120	3205	
E	200	200	250	280	300	350	400	450	500	550	600	610	610	610	610	610	610	610	
Weights(kg)	RF	23	35	50	71	100	144	209	322	482	683	950	1145	1634	2660	3090	3312	3597	
	BW	17	26	39	53	79	113	164	256	390	565	805	964	1412	2304	2540	2725	3057	

ANSI WEDGE GATE VALVES

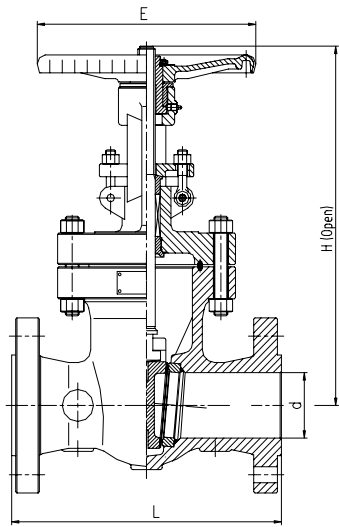

Class600

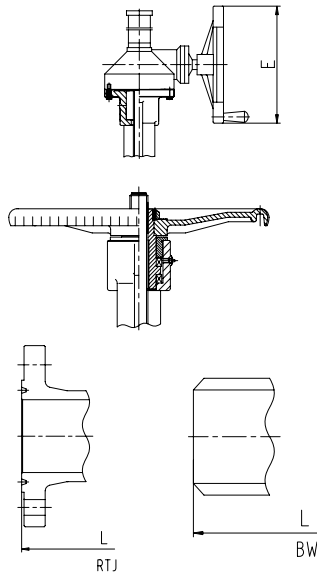

Class600 , NPS ≥ 10" and Class900、Class1500, NPS ≥ 6" With bearing , yoke and bonnet are bolted.

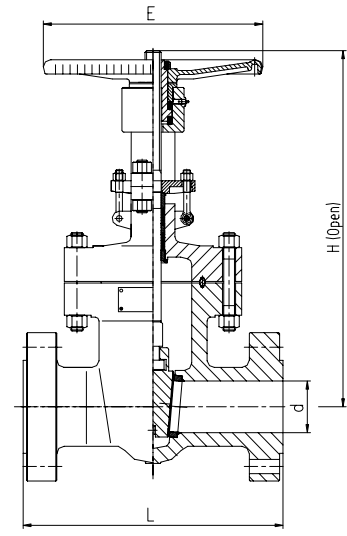

Class900~Class1500

Class600 , NPS ≥ 14" and Class900、Class1500 , NPS ≥ 8" With gear operation, Class600 , 8" ≤ NPS ≤ 12" and Class900、Class1500 , 4" ≤ NPS ≤ 6" Customer can choose gear operation or not.

Dimensions and Weights (Class600~Class1500)

Class		600															
NPS(in)		2	2 1/2	3	4	5	6	8	10	12	14	16	18	20	24		
Dimensions(mm)	d	51	64	76	102	127	152	203	254	305	337	387	438	489	591		
	L	RF/BW	292	330	356	432	508	559	660	787	838	889	991	1092	1194	1397	
		RTJ	295	333	359	435	511	562	663	790	841	892	994	1095	1200	1407	
	H	418	476	518	646	770	839	1024	1229	1450	1574	1797	1931	2207	2582		
	E	200	250	280	300	400	450	500	600	650	610	610	610	610	610	610	
Weights(kg)	RF	36	52	67	112	170	234	393	610	890	1245	1530	1967	2450	3620		
	BW	29	42	53	83	125	177	310	472	729	1054	1242	1626	2032	3017		
Class		900								1500							
NPS(in)		2	2 1/2	3	4	6	8	10	2	2 1/2	3	4	6	8	10		
Dimensions(mm)	d	51	64	76	102	152	203	254	51	64	76	102	146	194	241		
	L	RF/BW	368	419	381	457	610	737	838	368	419	470	546	705	832	991	
		RTJ	371	422	384	460	613	740	841	371	422	473	549	711	842	1000	
	H	498	547	573	678	900	1103	1345	487	572	603	700	984	1146	1371		
	E	280	300	300	350	550	600	610	280	300	350	400	550	460	460		
Weights(kg)	RF	74	131	101	172	335	640	1100	74	131	165	248	510	921	1910		
	BW	54	105	78	135	260	517	922	54	105	129	197	412	761	1640		

DIN WEDGE GATE VALVES

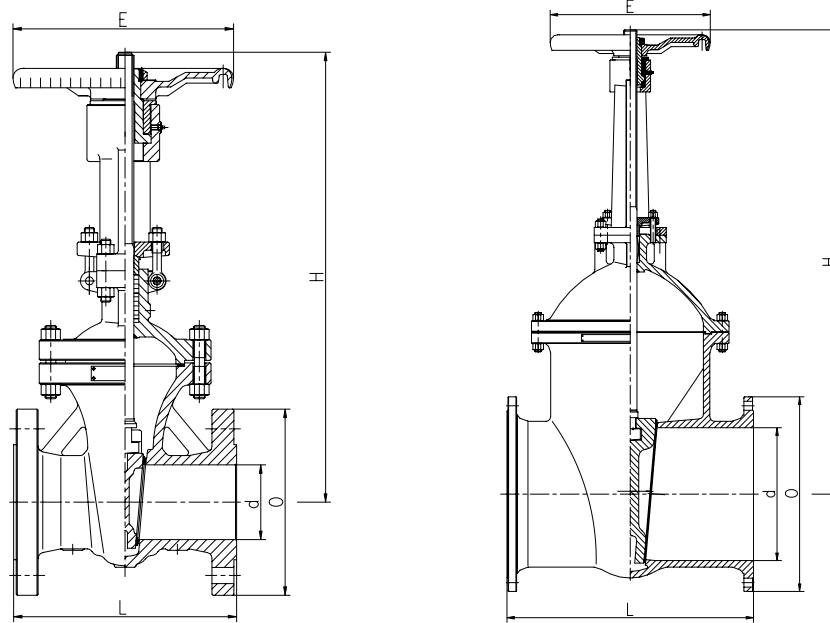

Dimensions and Weights (PN16~PN25)

PN		16													
DN(mm)		50	65	80	100	125	150	200	250	300	350	400	450	500	600
Dimensions (mm)	d	50	65	80	100	125	150	200	250	300	343	394	445	495	597
	L	250	270	280	300	325	350	400	450	500	550	600	650	700	800
	O	165	185	200	220	250	285	340	405	460	520	580	640	715	840
	H(Open)	387	435	481	585	681	765	956	1149	1351	1508	1703	1892	2119	2500
	E	200	200	250	280	280	300	350	400	450	500	550	600	600	650
Weights(kg)		19	25	30	55	75	98	150	245	353	490	750	985	1063	1390
PN		25													
DN(mm)		50	65	80	100	125	150	200	250	300	350	400	450	500	600
Dimensions (mm)	d	50	65	80	100	125	150	200	250	300	343	394	445	495	597
	L	250	270	280	300	325	350	400	450	500	550	600	650	700	800
	O	165	185	200	235	270	300	360	425	485	555	620	670	730	845
	H(Open)	387	435	481	585	681	765	956	1149	1351	1508	1703	1892	2119	2500
	E	200	200	250	280	280	300	350	400	450	500	550	600	600	650
Weights(kg)		19	25	30	55	82	103	180	265	385	547	835	1050	1130	1500

DIN WEDGE GATE VALVES

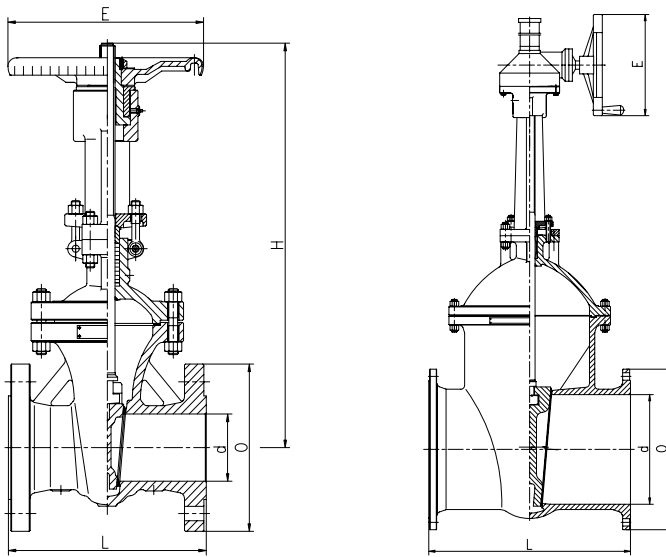

PN63, DN \geq 500 and
 PN100, DN \geq 200 With
 gear operation,
 PN63, 50 \leq DN \leq 400 and
 PN100, 50 \leq DN \leq 150 Customer
 can choose gear operation
 or not.

Dimensions and Weights (PN40~PN100)

PN		40													
DN(mm)		50	65	80	100	125	150	200	250	300	350	400	450	500	600
Dimensions (mm)	d	50	65	80	100	125	150	200	250	300	336	387	432	483	584
	L	250	290	310	350	400	450	550	650	750	850	950	1050	1150	1350
	O	165	185	200	235	270	300	375	450	515	580	660	685	755	890
	H(Open)	410	453	509	612	670	805	1000	1209	1416	1582	1725	1959	2194	2598
	E	200	200	250	280	300	350	400	450	500	550	600	600	750	900
Weights(kg)		20	32	47	60	95	130	220	290	490	760	900	1250	1450	1700
PN		63													
DN(mm)		50	65	80	100	125	150	200	250	300	350	400	500	600	—
Dimensions (mm)	d	50	65	80	100	125	150	200	250	300	336	387	483	584	—
	L	250	290	310	350	400	450	550	650	750	850	950	1150	1350	—
	O	180	205	215	250	295	345	415	470	530	600	670	800	930	—
	H(Open)	418	476	518	646	770	839	1024	1229	1450	1574	1797	2207	2582	—
	E	200	250	280	300	400	450	500	600	650	800	900	610	610	—
Weights(kg)		22	35	52	66	103	140	230	300	510	780	940	1600	1850	—
PN		100													
DN(mm)		50	65	80	100	125	150	200	250	300	350	400	500	—	—
Dimensions (mm)	d	50	65	80	100	125	150	200	250	300	336	387	483	—	—
	L	250	290	310	350	400	450	550	650	750	850	950	1150	—	—
	O	195	220	230	265	315	355	430	505	585	655	715	870	—	—
	H(Open)	498	547	573	678	728	900	1103	1345	1605	1770	2035	2485	—	—
	E	280	300	300	350	450	550	600	700	800	550	600	750	—	—
Weights(kg)		25	39	58	74	113	152	242	323	533	803	990	1860	—	—

DIN SHORT-PATTERN WEDGE GATE VALVES

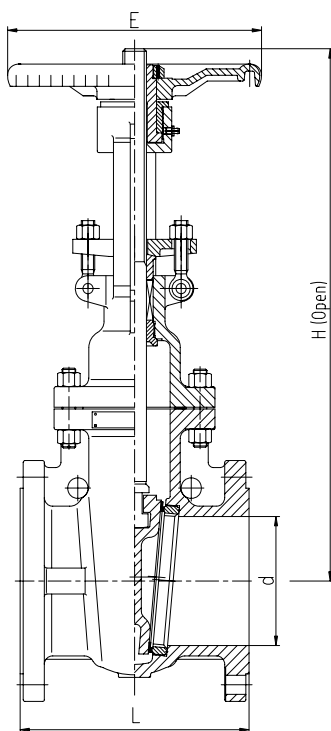

Dimensions and Weights (PN10~PN16)

PN		10													
DN(mm)		50	65	80	100	125	150	200	250	300	350	400	450	500	600
Dimensions (mm)	d	50	65	80	100	125	150	200	250	300	343	394	445	495	597
	L	150	170	180	190	200	210	230	250	270	290	310	330	350	390
	O	165	185	200	220	250	285	340	395	445	505	565	615	670	780
	H(Open)	387	435	481	585	681	765	956	1149	1351	1508	1703	1892	2119	2500
	E	200	200	250	280	280	300	350	400	450	500	550	600	600	650
Weights(kg)		16	23	28	42	72	84	134	216	320	470	730	965	1043	1372
PN		16													
DN(mm)		50	65	80	100	125	150	200	250	300	350	400	450	500	600
Dimensions (mm)	d	50	65	80	100	125	150	200	250	300	343	394	445	495	597
	L	150	170	180	190	200	210	230	250	270	290	310	330	350	390
	O	165	185	200	220	250	285	340	405	460	520	580	640	715	840
	H(Open)	387	435	481	585	681	765	956	1149	1351	1508	1703	1892	2119	2500
	E	200	200	250	280	280	300	350	400	450	500	550	600	600	650
Weights(kg)		16	23	28	42	72	84	134	216	320	470	730	965	1043	1372

PRESSURE SEAL GATE VALVES

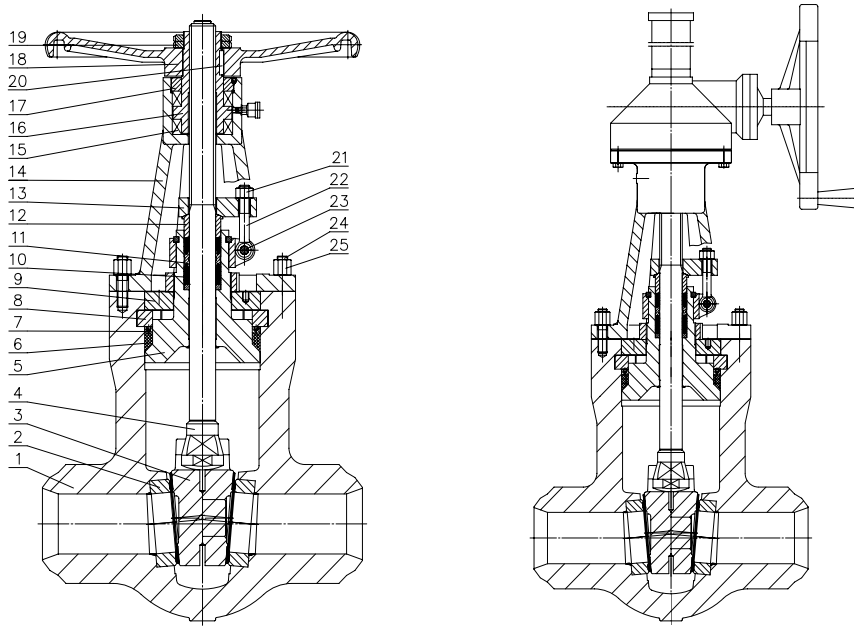

Material Specifications

NO.	Parts	Materials				
		Standard	High Temperature			Corrosion Service
1	Body	A216 WCB	A217 WC6	A217 WC9	A217 C5	A351 CF8M
2	Seat	A105①	A182 F11①	A182 F22①	A182 F5a①	A182 F316①
3	Gate	A216 WCB①	A217 WC6①	A217 WC9①	A217 C5①	A351 CF8M①
4	Stem	A276 410	A276 410	A276 410	A276 410	A276 316
5	Valve Core	A216 WCB	A217 WC6	A217 WC9	A217 C5	A351 CF8M
6	Seal Ring	Graphite+304	Graphite+304	Graphite+304	Graphite+304	Graphite+304
7	Gland Flange Ring	A276 410	A276 410	A276 410	A276 410	A276 316
8	Segment Ring	A276 410	A276 410	A276 410	A276 410	A276 316
9	Supporting Plate	A105	A182 F11	A182 F22	A182 F5a	A182 F316
10	Lantern Ring	A276 410	A276 410	A276 410	A276 410	A276 316
11	Packing	Graphite	Graphite	Graphite	Graphite	Graphite
12	Gland	A276 410	A276 410	A276 410	A276 410	A276 316
13	Gland Flange	CS	CS	CS	CS	CS
14	Yoke	A216 WCB	A217 WC6	A217 WC9	A217 C5	A351 CF8
15	Bearing	Assembly	Assembly	Assembly	Assembly	Assembly
16	Stem Nut	Bronze	Bronze	Bronze	Bronze	Bronze
17	Stem Nut Retainer	ASTM A29	ASTM A29	ASTM A29	ASTM A29	ASTM A29
18	Handwheel	Cast Iron	Cast Iron	Cast Iron	Cast Iron	Cast Iron
19	Handwheel Nut	ASTM A29 + Zn	ASTM A29 + Zn	ASTM A29 + Zn	ASTM A29 + Zn	ASTM A29 + Zn
20	Set Screw	CS	CS	CS	CS	CS
21	Nut	A194 2H	A194 2H	A194 2H	A194 2H	A194 8
22	Eyebolt	A193 B7	A193 B7	A193 B7	A193 B7	A193 B8
23	Pin	ASTM A29	ASTM A29	ASTM A29	ASTM A29	ASTM A29
24	Bolt	A193 B7	A193 B7	A193 B7	A193 B7	A193 B8
25	Nut	A194 2H	A194 2H	A194 2H	A194 2H	A194 8

Note: ① Seal surface materials can be designed according to customer's requirement.

ANSI PRESSURE SEAL GATE VALVES

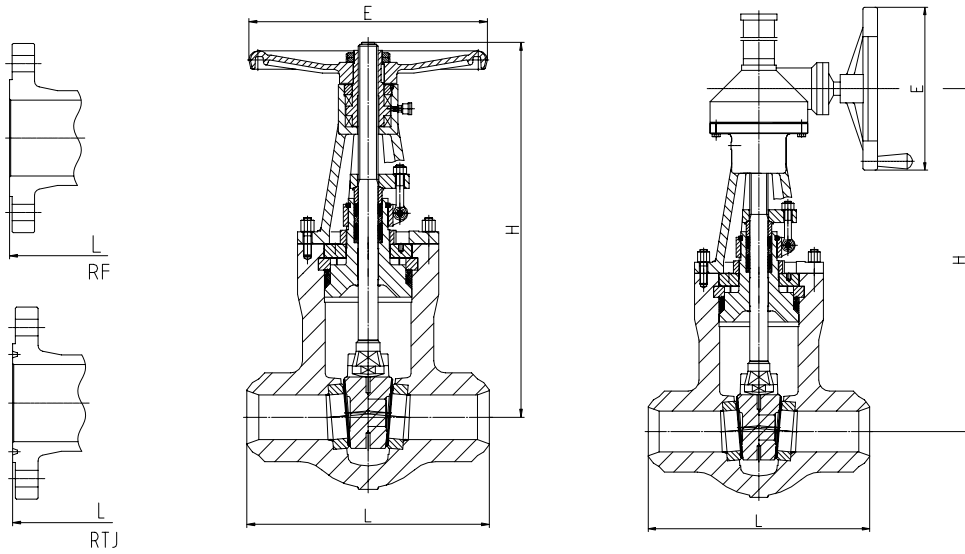

Manual
NPS ≤ 4"

Gear Operation
Class 900 , NPS ≥ 8"
Class 1500 , NPS ≥ 8"
Class 2500 , NPS ≥ 6"

Dimensions and Weights (Class 900 ~ Class 2500)

Class		900										
NPS(in)		2	2 1/2	3	4	6	8	10	12	14	16	
Dimensions(mm)	d	51	64	76	102	152	203	254	305	325	375	
	L	RF	368	419	381	457	610	737	838	965	1029	1130
		BW	216	254	305	356	508	660	787	914	991	1092
		RTJ	371	422	384	460	613	740	841	968	1038	1140
	H (Open)	594	753	756	864	1013	1276	1543	1781	2026	2261	
E	250	250	300	350	500	600	610	610	610	610	610	
Weights(kg)	RF	63	99	107	158	294	693	1008	1418	1785	2520	
	BW	42	67	84	105	194	520	772	1103	1470	2048	
Class		1500										
NPS(in)		2	2 1/2	3	4	6	8	10	12	14	16	
Dimensions(mm)	d	51	64	76	102	146	194	241	289	317	362	
	L	RF	368	419	470	546	705	832	991	1130	1257	1384
		BW	216	254	305	406	559	711	864	991	1067	1194
		RTJ	371	422	473	549	711	842	1000	1146	1276	1407
	H (Open)	594	753	756	864	994	1349	1480	1870	2216	2331	
E	250	300	350	500	600	458	458	610	610	610		
Weights(kg)	RF	63	99	126	218	504	956	1481	2184	2741	3780	
	BW	42	67	84	155	367	718	1071	1523	1890	2888	
Class		2500										
NPS(in)		2	2 1/2	3	4	6	8	10	12	—	—	
Dimensions(mm)	d	44	54	64	89	133	181	225	267	—	—	
	L	RF	451	508	578	673	914	1022	1270	1422	—	—
		BW	279	330	368	457	610	762	914	1041	—	—
		RTJ	454	514	584	683	927	1038	1292	1445	—	—
	H (Open)	594	753	756	870	1129	1389	1748	1873	—	—	
E	350	450	450	500	610	610	610	610	—	—		
Weights(kg)	RF	89	142	173	346	851	1386	2493	3091	—	—	
	BW	53	95	100	200	488	850	1680	2330	—	—	

GLOBE VALVES

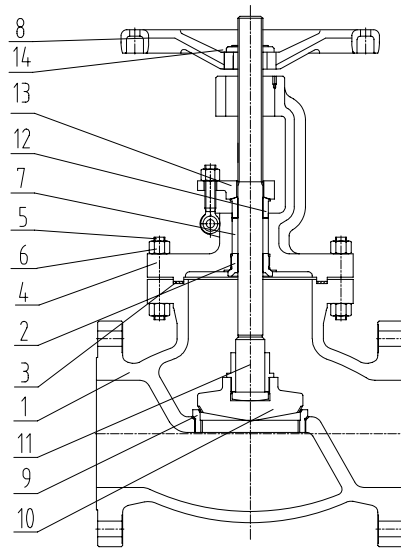

Material Specifications

NO.	Parts	Materials			
		Standard	Low Temp. Service	High Temp. Service	Stainless Steel
1	Body	A216 WCB	A352 LCB	A217 WC6	A351 CF8M
2	Backseat	A182 F6a	A182 F304	A182 F304	A182 F316
3	Bonnet Gasket	Graphite + 304	Graphite + 304	Graphite + 304	Graphite + 304
4	Bonnet	A216 WCB	A352 LCB	A217 WC6	A351 CF8M
5	Bonnet bolt	A193 B7	A320 L7	A193 B16	A193 B7M
6	Bonnet Nut	A194 2H	A194 4	A194 4	A194 2HM
7	Packing	Flexible Graphite+304	Flexible Graphite+304	Flexible Graphite+304	Flexible Graphite+304
8	Handwheel	Cast Iron	Cast Iron	Cast Iron	Cast Iron
9	Seat	A105①	A182 LF2①	A182 F11①	A182 F316①
10	Disc	A105①	A182 LF2①	A182 F11①	A182 F316①
11	Stem	A182 F6a	A182 F304	A182 F6a	A182 F316
12	Gland	A276 410	A276 410	A276 304	A276 304
13	Gland Flange	CS	CS	CS	CS
14	Stem Nut	A439 D2 / Bronze	A439 D2 / Bronze	A439 D2 / Bronze	A439 D2 / Bronze

Note : ①Seal surface materials can be designed according to customer's requirement.

ANSI GLOBE VALVES

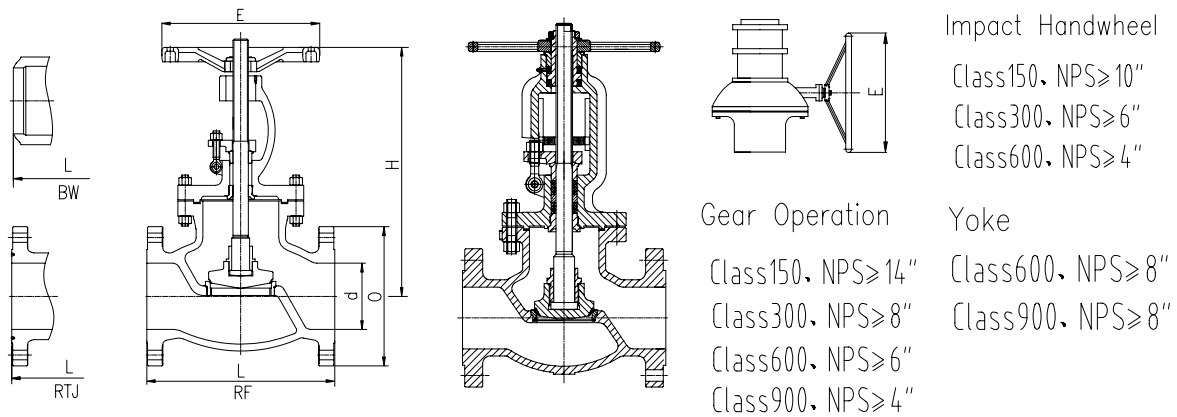

Dimensions and Weights (Class150 ~ Class900)

Class	NPS(in)	Dimensions (mm)						Weights (kg)	
		d	L		O	H(Open)	E	RF/RTJ	BW
			RF / BW	RTJ					
150	2	51	203	216	150	338	200	21	17
	2 1/2	64	216	229	180	373	250	28	20
	3	76	241	254	190	396	250	35	27
	4	102	292	305	230	476	300	58	47
	6	152	406	419	280	524	350	100	86
	8	203	495	508	345	588	400	160	138
	10	252	622	635	405	738	550	253	219
	12	305	698	711	485	862	600	398	362
	14	337	787	800	535	950	610	550	491
	16	387	914	927	595	994	610	724	650
300	2	51	267	283	165	354	200	25	19
	2 1/2	64	292	308	190	389	250	38	29
	3	76	318	333	210	421	250	49	38
	4	102	356	371	255	496	350	76	58
	6	152	444	460	320	675	500	168	137
	8	203	559	575	380	912	560	282	237
	10	252	622	638	445	949	600	385	319
	12	305	711	727	520	1032	650	724	632
	14	337	838	854	585	1130	610	1125	975
600	2	51	292	295	165	397	250	36	29
	2 1/2	64	330	333	190	446	250	50	40
	3	76	356	359	210	496	350	78	64
	4	102	432	435	275	599	450	120	91
	6	152	559	562	355	791	560	284	227
	8	200	660	663	420	1014	600	543	460
	10	248	787	790	510	1180	700	700	562
	12	298	838	841	560	1397	610	900	739
900	2	47	368	371	165	590	350	95	75
	2 1/2	57	419	422	190	660	350	138	112
	3	73	381	384	240	699	450	108	85
	4	98	457	460	290	795	500	195	158
	6	146	610	613	380	1108	610	435	360
	8	191	737	740	470	1184	610	720	597

DIN GLOBE VALVES

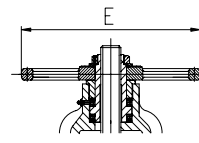
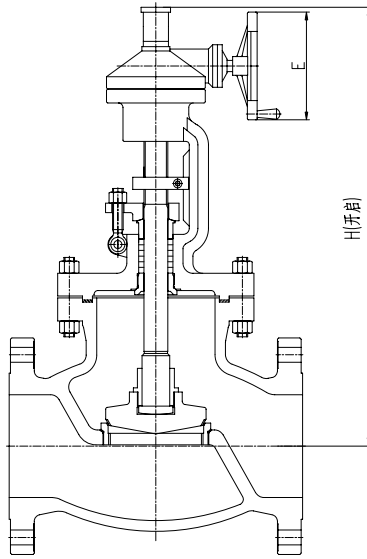
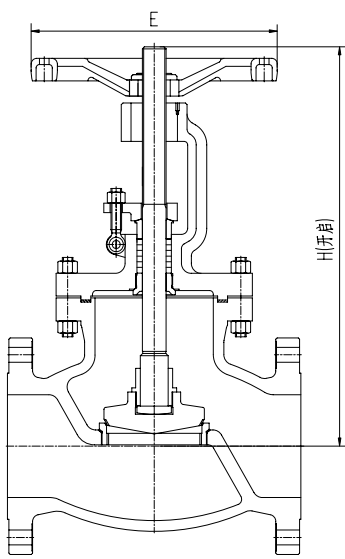

Yoke
 PN63, DN ≥ 200
 PN100, DN ≥ 200

Impact Handwheel

PN16, PN25, DN ≥ 250
 PN40, DN ≥ 150
 PN63, DN ≥ 100

Gear Operation

PN16, PN25, DN ≥ 350
 PN40, DN ≥ 200
 PN63, DN ≥ 150
 PN100, DN ≥ 100

Dimensions and Weights (PN16~PN100)

DN (mm)		50	65	80	100	150	200	250	300	350	400
L(mm)		230	290	310	350	480	600	730	850	980	1100
PN16	H(mm)	305	354	402	437	541	699	815	914	1189	1350
	E(mm)	200	250	250	300	350	400	550	600	560	650
	Weights (kg)	20	25	35	50	100	210	446	648	805	1050
PN25	H(mm)	325	363	415	453	556	744	864	948	1269	1450
	E(mm)	200	250	250	300	350	400	550	600	560	650
	Weights (kg)	22	27	38	55	105	220	450	660	810	1100
PN40	H(mm)	325	370	430	480	589	783	888	965	1285	1512
	E(mm)	200	250	250	350	500	560	600	650	610	610
	Weights (kg)	24	30	41	60	110	225	460	670	830	1120
DN (mm)		50	65	80	100	150	200	250	300	350	400
L(mm)		300	340	380	430	550	650	775	900	1025	1150
PN63	H(mm)	305	354	402	437	541	699	815	914	1189	1350
	E(mm)	250	250	350	450	560	600	700	610	610	610
	Weights (kg)	26	33	45	65	120	230	470	680	850	1130
PN100	H(mm)	325	363	415	453	556	744	864	948	1269	1450
	E(mm)	350	350	450	500	610	610	610	610	610	610
	Weights (kg)	27	34	46	67	125	235	480	690	860	1150

ANSI PRESSURE SEAL GLOBE VALVES

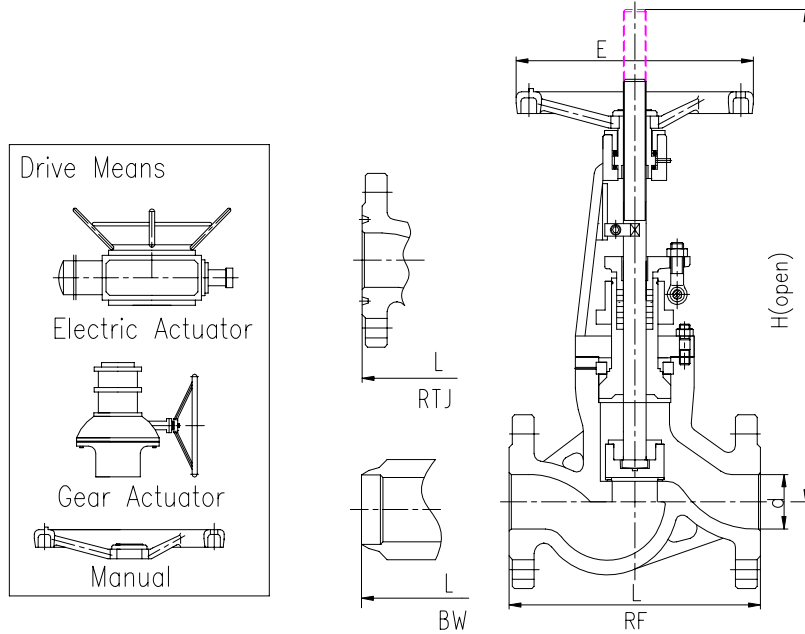

Dimensions and Weights(Class900~Class2500)

Class	NPS(in)	Dimensions(mm)						Weights(kg)	
		d	L		O	H(Open)	E	Weights(kg)	
			RF / BW	RTJ				RF/RTJ	BW
900	2	47	368	371	165	619	350	84	58
	2 1/2	57	419	422	190	641	350	116	84
	3	73	381	384	240	721	450	110	84
	4	98	457	460	290	850	500	179	137
	6	146	610	613	380	1225	610	441	378
	8	191	737	740	470	1350	610	1050	945
1500	2	47	368	371	215	619	350	84	58
	2 1/2	57	419	422	245	641	350	116	84
	3	70	470	473	265	835	500	143	100
	4	92	546	549	310	857	560	236	168
	6	136	705	711	395	1230	610	918	781
	8	178	832	842	485	1800	610	1764	1502
2500	2	38	451	454	235	616	400	105	74
	2 1/2	47	508	541	265	781	500	163	116
	3	57	578	584	305	800	560	221	147
	4	73	673	683	355	1300	610	525	368
	6	111	914	927	485	1370	610	1313	973
	8	146	1022	1038	550	2160	610	2520	2100

Note: Manual for 4" and smaller.

SWING CHECK VALVES

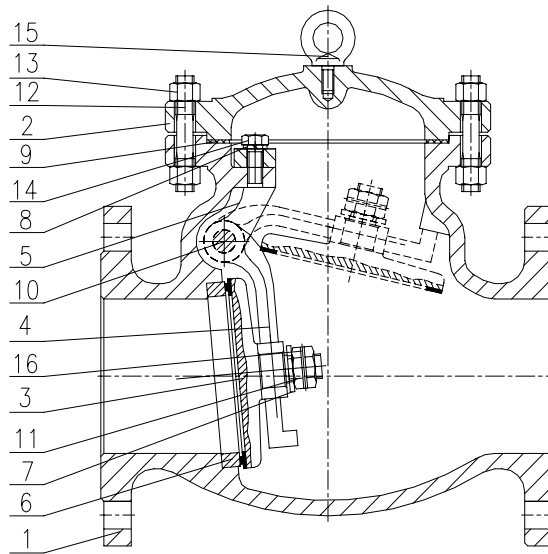

Material Specifications

No.	Parts	Materials			
		Standard	Sour(NACE)	Low Temperature	High Temperature
1	Body	A216 WCB	A216 WCB	A352 LCC	A217 C5
2	Bonnet	A216 WCB	A216 WCB	A352 LCC	A217 C5
3	Disc	A216 WCB①	A351 CF8①	A352 LCC①	A217 C5①
4	Hinge	A216 WCB	A216 WCB	A352 LCC	A217 C5
5	Yoke	A216 WCB	A216 WCB	A352 LCC	A217 C5
6	Seat	A105①	A182 F304①	A350 LF3①	A182 F5a①
7	Disc Washer	Carbon Steel	AISI 316	AISI 316	AISI 316
8	Bolt Washer	Carbon Steel	AISI 316	AISI 316	AISI 316
9	Gasket	Flexible Graphite + SS	Flexible Graphite + SS	Flexible Graphite + SS	Flexible Graphite + SS
10	Hinge Pin	A276 410	A182 F316	A182 F316	A276 410
11	Disc Nut	A182 F304	A182 F304	A182 F304	A182 F304
12	Bonnet Bolt	A193 B7	A193 B7M	A320 L7M	A193 B16
13	Bonnet Nut	A194 2H	A194 2HM	A194 7M	A194 4
14	Bolt	A276 304	A276 304	A276 304	A276 304
15	Eyebolt	CS	CS	CS	CS
16	Disc Pin	A276 304	A276 304	A276 304	A276 304

Notes: ① Seal surface materials can be designed according to customer's requirement.

ANSI SWING CHECK VALVES

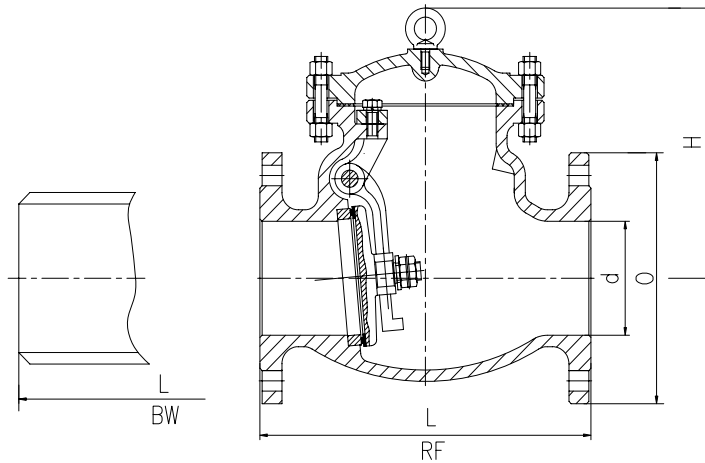

Dimensions and Weights(Class150~Class300)

Class	NPS(in)	Dimensions(mm)				Weights(kg)	
		d	L	O	H	RF	BW
			RF/BW				
150	2	51	203	150	150	15	12
	2 1/2	64	216	180	170	26	17
	3	76	241	190	180	27	18
	4	102	292	230	237	42	32
	6	152	356	280	305	75	60
	8	203	495	345	370	124	106
	10	254	622	405	420	200	174
	12	305	698	485	440	310	258
	14	337	787	535	470	428	368
	16	387	864	595	520	555	483
	18	438	978	635	580	775	685
	20	489	978	700	630	835	720
	24	591	1295	815	870	1100	970
	26	635	1295	870	901	1370	1120
	28	686	1448	927	920	1720	1550
30	737	1524	984	970	1980	1780	
300	2	51	267	165	170	21	15
	2 1/2	64	292	190	185	30	22
	3	76	318	210	215	39	30
	4	102	356	255	235	70	44
	6	152	444	320	300	125	98
	8	203	533	380	340	190	150
	10	254	622	445	350	290	230
	12	305	711	520	420	450	375
	14	337	838	585	480	700	555
	16	387	864	650	520	840	766
	18	438	978	710	600	1000	915
	20	489	1016	775	670	1273	1100
	24	591	1346	915	750	1700	1500
	26	635	1346	972	880	2175	1995
	28	686	1499	1035	1010	2565	2260
30	737	1594	1092	1410	2989	2680	

ANSI SWING CHECK VALVES

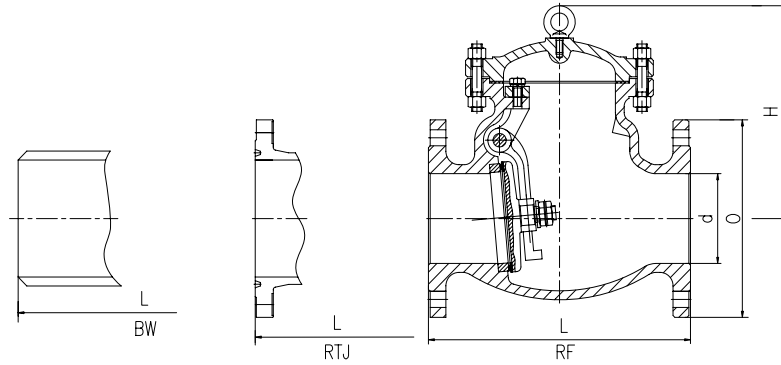

Dimensions and Weights (Class600~Class1500)

Class	NPS(in)	Dimensions (mm)					Weights(kg)	
		d	L		O	H	Weights(kg)	
			RF/BW	RTJ			RF/RTJ	BW
600	2	51	292	295	165	175	28	20
	2 1/2	64	330	333	190	200	38	30
	3	76	356	359	210	230	52	40
	4	102	432	435	275	295	87	65
	6	152	559	562	355	360	224	155
	8	203	660	664	420	400	354	280
	10	254	787	791	510	460	555	395
	12	305	838	841	560	520	790	630
	14	336	889	892	605	590	892	710
	16	387	991	994	685	670	1200	1020
18	438	1092	1095	745	730	1600	1350	
900	2	51	368	371	165	300	70	50
	2 1/2	64	419	422	190	310	100	77
	3	76	381	384	240	310	91	68
	4	102	457	460	290	335	150	113
	6	152	610	613	380	420	305	230
	8	203	737	740	470	503	510	387
	10	254	838	841	545	637	810	632
	12	305	965	968	610	757	1120	901
	14	324	1029	1038	640	810	1380	1139
16	375	1130	1140	705	820	1900	1613	
1500	2	51	368	371	215	300	70	50
	2 1/2	64	419	422	245	300	100	77
	3	76	470	473	265	340	150	115
	4	102	546	549	310	411	285	190
	6	146	705	711	395	511	550	452
	8	194	832	841	485	681	1010	845
	10	241	991	1000	585	757	1550	1280
	12	289	1130	1146	675	856	2280	1780

DIN SWING CHECK VALVES

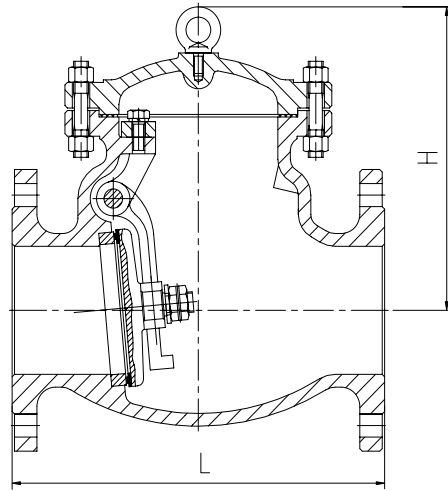

Dimensions and Weights (PN16~PN100)

DN		50	65	80	100	125	150	200	250	300	350	400	500	600
PN16	L(mm)	200	240	260	300	350	400	500	600	700	800	900	1100	1300
	H(mm)	150	170	180	237	270	305	369	424	440	470	520	630	870
	WT(kg)	16	25	29	44	68	85	115	180	270	380	509	967	1507
PN25	L(mm)	230	290	310	350	400	480	600	730	850	980	1100	1250	1450
	H(mm)	150	170	180	237	270	305	369	424	440	470	520	630	870
	WT(kg)	17	30	34	48	105	118	160	230	420	535	585	1025	1650
PN40	L(mm)	230	290	310	350	400	480	600	730	850	980	1100	1250	1450
	H(mm)	150	170	180	237	270	305	369	424	440	470	520	630	870
	WT(kg)	17	30	34	48	105	118	220	320	450	600	800	1269	1669
PN63	L(mm)	300	340	380	430	500	550	650	775	900	1025	1150	1400	—
	H(mm)	180	200	220	245	300	335	385	445	520	565	635	750	—
	WT(kg)	37	45	55	59	145	160	255	360	600	780	1100	1656	—
PN100	L(mm)	300	340	380	430	500	550	650	775	900	1025	1150	1400	—
	H(mm)	180	200	220	245	300	335	385	445	520	585	635	950	—
	WT(kg)	80	95	110	125	190	260	400	560	800	1000	1250	1925	—

PRESSURE SEAL CAST STEEL SWING CHECK VALVES

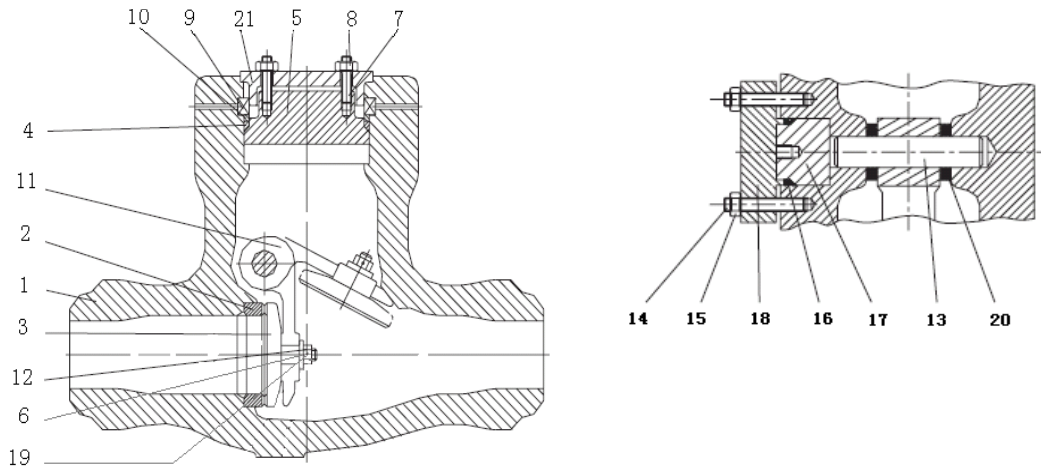

Material Specifications

No.	Parts	Materials		
1	Body	A216 WCB	A217 WC6	A217 WC9
2	Seat(1)	A105①	A182 F22①	A182 F22①
3	Disc	A216 WCB①	A217 WC9①	A217 WC9①
4	Gasket	316 Reinforced Graphite	316 Reinforced Graphite	316 Reinforced Graphite
5	Bonnet	A105	A182 F22	A182 F22
6	Washer	A182 F316	A182 F316	A182 F316
7	Bonnet Bolt	A193 B7	A193 B16	A193 B16
8	Bonnet Nut	A194 2H	A194 4	A194 4
9	Segment Ring	A276 410	A276 410	A276 410
10	Intermediate Thrust Ring	A276 410	A276 410	A276 410
11	Hinge	A216 WCB	A217 WC6	A217 WC9
12	Disc Nut	A194 2H	A194 4	A194 4
13	Hinge Pin	A182 F6a	A182 F6a	A182 F6a
14	Plug Bolt	A193 B7	A193 B16	A193 B16
15	Plug Nut	A194 2H	A194 4	A194 4
16	Pin Gasket	316 Reinforced Graphite	316 Reinforced Graphite	316 Reinforced Graphite
17	Pressure Seal Plug	A105	A182 F22	A182 F22
18	Flange	A105	A182 F22	A 182 F22
19	Pin	A276 316	A276 316	A276 316
20	Spacer	A182 F316	A182 F316	A182 F316
21	Retaining Ring	A105	A105	A105

Notes: (1) Seats are welded in.

① Seal surface materials can be designed according to customer's requirement.

ANSI PRESSURE SEAL CAST STEEL SWING CHECK VALVES

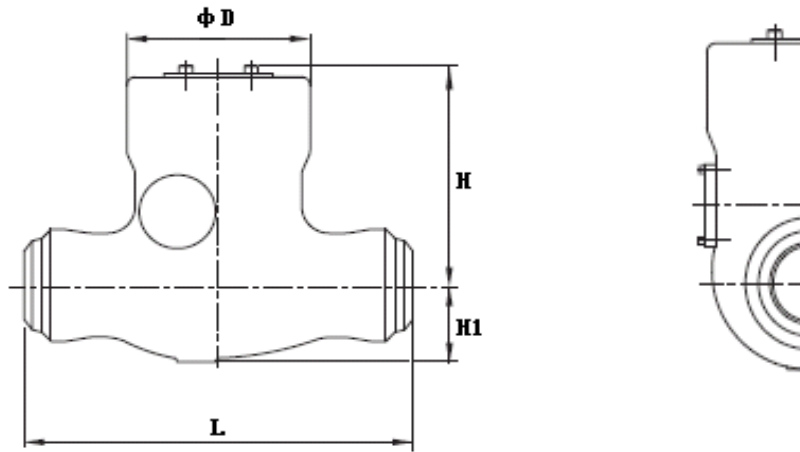

Dimensions and Weights (Class900~Class1500)

NPS(in)		2	2 1/2	3	4	6	8	10	12	14	16
Class900	L(mm)	*	254	305	356	508	660	787	914	991	1092
	D(mm)	160	160	170	192	270	340	396	420	516	580
	H(mm)	230	230	240	265	310	405	455	475	540	620
	H1(mm)	65	65	70	85	115	145	170	200	225	250
	WT(kg)	35	35	45	52	115	280	380	560	665	950
Class1500	L(mm)	216	254	305	406	559	711	864	991	1067	1194
	D(mm)	160	160	170	230	285	380	430	500	540	620
	H(mm)	230	230	235	260	350	440	490	535	595	700
	H1(mm)	65	65	75	95	125	170	190	225	245	275
	WT(kg)	35	35	53	60	140	360	465	790	1040	1490

Notes: * Dimensions can be designed according to customer's requirement.

LIFT CHECK VALVE

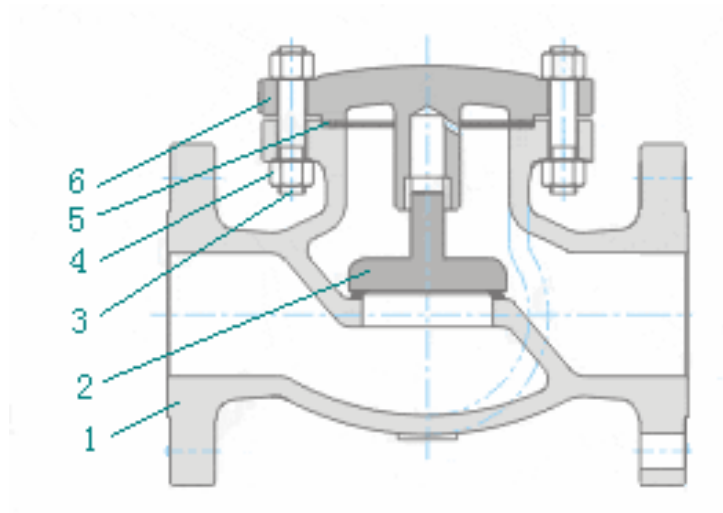

Material Specifications

No.	Parts	Materials			
		Standard	Sour(NACE)	Low Temperature	High Temperature
1	Body	A216 WCB①	A216 WCB①	A352 LCC①	A217 C5①
2	Disc	A105①	A182 F316①	A350 LF3①	A182 F5a①
3	Bolt	A193 B7	A193 B7M	A320 L7M	A193 B8M
4	Nut	A194 2H	A194 2HM	A194 7M	A194 8M
5	Gasket	Flexible Graphite +SS	Flexible Graphite +SS	Flexible Graphite +SS	Flexible Graphite +SS
6	Bonnet	A216 WCB	A216 WCB	A352 LCC	A217 C5

Notes: ①Seal surface materials can be designed according to customer is requirement.

ANSI LIFT CHECK VALVES

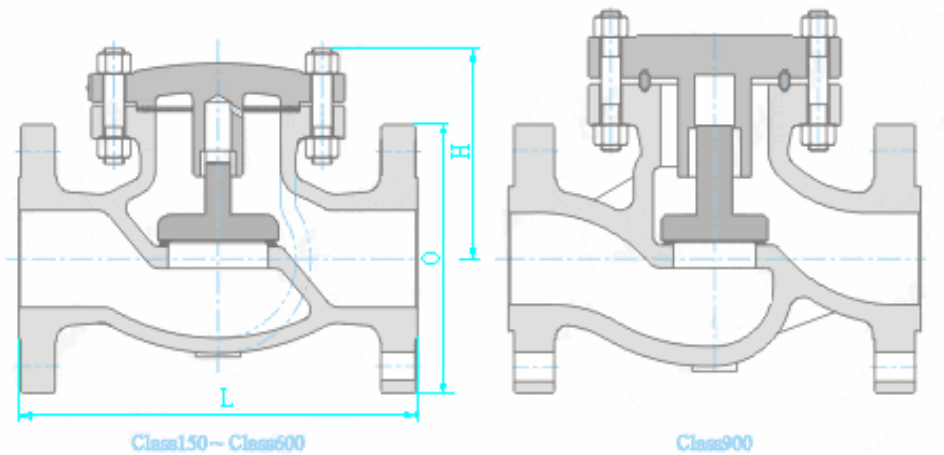

Dimensions and Weights (Class150~Class900)

Class		150									
NPS(in)		2	2 1/2	3	4	6	8	10	12	14	16
Dimensions (mm)	L	203	216	241	292	406	495	622	698	787	914
	O	150	180	190	230	280	345	405	485	535	595
	H	165	175	190	215	265	320	365	415	460	510
WT(kg)		17	25	29	50	85	150	240	350	460	580
Class		300									
NPS(in)		2	2 1/2	3	4	6	8	10	12	—	—
Dimensions (mm)	L	267	292	318	356	444	559	622	711	—	—
	O	165	190	210	255	320	380	445	520	—	—
	H	190	205	220	245	295	330	420	480	—	—
WT(kg)		28	33	45	70	150	230	390	520	—	—
Class		600									
NPS(in)		2	2 1/2	3	4	6	8	10	12	—	—
Dimensions (mm)	L	292	330	356	432	559	660	787	838	—	—
	O	165	190	210	275	355	420	510	560	—	—
	H	210	230	255	295	365	420	505	545	—	—
WT(kg)		33	43	62	113	222	390	630	871	—	—
Class		900									
NPS(in)		2	2 1/2	3	4	6	—	—	—	—	—
Dimensions (mm)	L	368	419	381	457	610	—	—	—	—	—
	O	165	190	240	290	380	—	—	—	—	—
	H	235	270	302	342	425	—	—	—	—	—
WT(kg)		120	166	176	182	403	—	—	—	—	—

PRESSURE SEAL CAST STEEL TILTING DISC CHECK VALVES

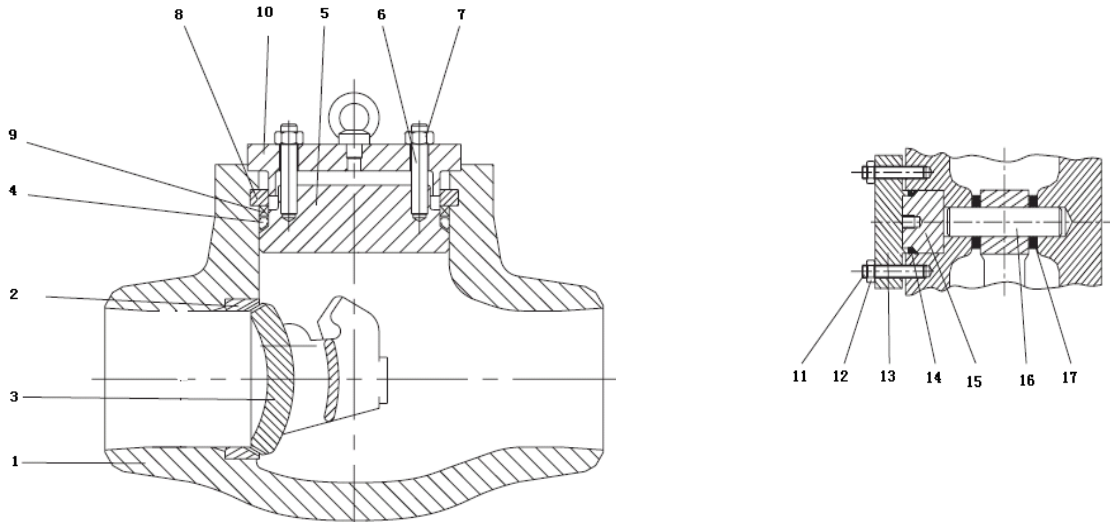

Material Specifications

NO.	Parts	Materials		
1	Body	A216 WCB	A217 WC6	A217 WC9
2	Seat(1)	A105①	A182 F22①	A182 F22①
3	Disc	A216 WCB①	A217 WC9①	A217 WC9①
4	Gasket	316 + Flexible Graphite	316 + Flexible Graphite	316 + Flexible Graphite
5	Bonnet	A105	A182 F22	A182 F22
6	Bonnet Bolt	A193 B7	A193 B16	A193 B16
7	Bonnet nut	A194 2H	A194 4	A194 4
8	Segment Ring	A276 410	A276 410	A276 410
9	Intermediate Thrust Ring	A276 410	A276 410	A276 410
10	Retaining Ring	A105	A105	A105
11	Bolt	A193 B7	A193 B16	A193 B16
12	Nut	A194 2H	A194 4	A194 4
13	Flange	A105	A182 F22	A182 F22
14	Gasket	316+Flexible Graphite	316+Flexible graphite	316+Flexible graphite
15	Pressure Seal Plug	A105	A182 F22	A182 F22
16	Pin	A182 F6a	A182 F6a	A182 F6a
17	Spacer	A182 F316	A182 F316	A182 F316

Notes:(1)Seats are welded in.

①Seal surface materials can be designed according to customer's requirement.

ANSI PRESSURE SEAL CAST STEEL TILTING DISC CHECK VALVES

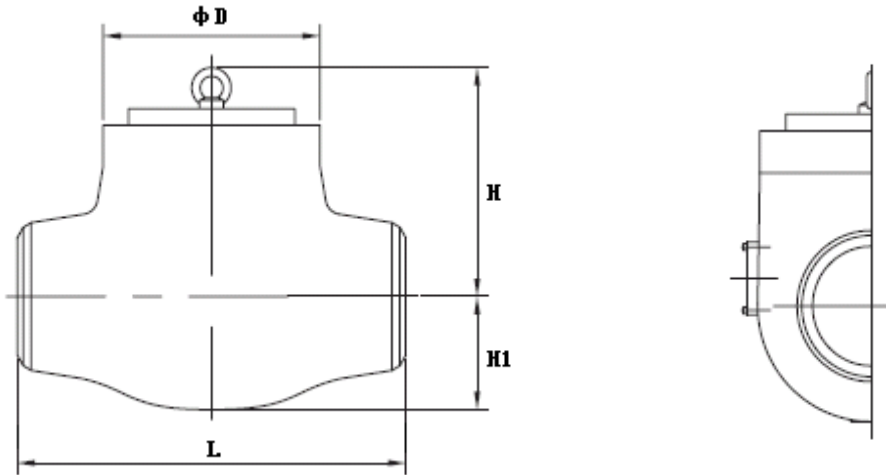

Dimensions and Weights (Class1500~Class2500)

NPS(in)		2	3	4	6	8	10	12	14	16	18	20	24
Class1500	L(mm)	*	305	406	559	711	864	991	1067	1194	1346	1473	1500
	D(mm)	170	185	215	260	365	455	480	510	665	745	860	990
	H(mm)	185	185	295	380	460	610	700	730	790	840	900	980
	H1(mm)	80	110	120	145	180	230	260	280	335	380	445	565
	WT(kg)	60	65	110	270	530	780	1210	1490	2170	2825	4150	5200
Class2500	L(mm)	279	368	457	610	762	914	1041	1118	1245	1397	1500	1500
	D(mm)	170	170	185	285	365	420	465	520	560	650	710	815
	H(mm)	160	160	185	360	360	450	580	620	775	855	890	970
	H1(mm)	80	80	120	165	180	210	250	275	335	345	385	465
	WT(kg)	60	65	105	245	520	860	1250	1750	2350	3200	4540	5700

Notes: * Dimensions can be designed according to customer's requirement.

FORGED STEEL GATE VALVES

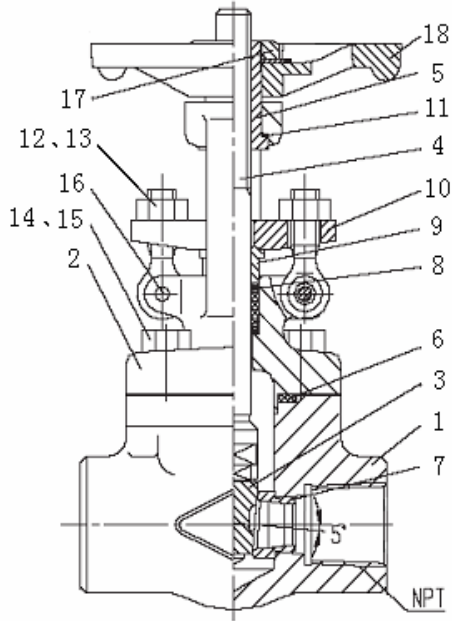

Technical Data

Pressure Ratings: Class800~Class1500

Basic Design : API 602

End Threads: ASME B 1.20.1

Socket-weld: ASME B 16.11

Test and Inspection: API 598

Material Specifications

No.	Parts	Materials
		ASTM
1	Body	A105
2	Bonnet	A105
3	Gate	A217①
4	Stem	A182 F6a
5	Stem Nut	A439 D2 / Bronze
6	Gasket	304 SS
7	Seat	A105①
8	Packing	304 + Flexible Graphite
9	Gland	A276 420
10	Gland Flange	CS
11	Thrust Washer	A182 F304
12	Nut	A194 2H
13	Eyebolt	A193 B7
14	Bolt	A193 B7
15	Nut	A194 2H
16	Pin	CS
17	Handwheel Nut	CS
18	Handwheel	Cast Iron

Note: ①Seal surface materials can be designed according to customer's requirement.

ANSI FORGED STEEL GATE VALVES

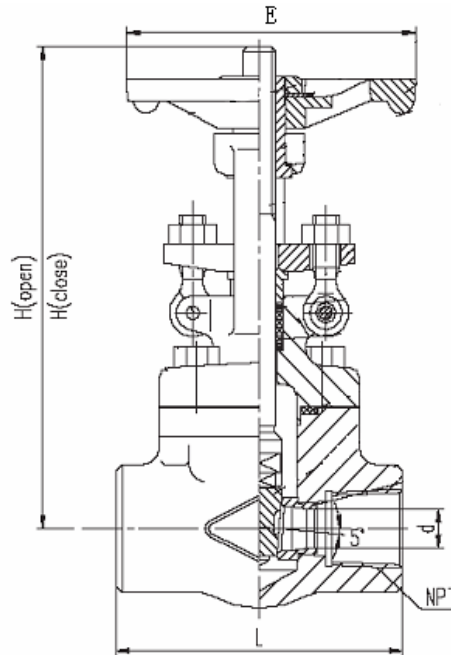

Dimensions and Weights (Class800~Class1500)

Class	NPS(in)	Dimensions(mm)					Weights(kg)
		d	L	H		E	
				Open	Close		
800	1/4	6.4	76	146	132.5	80	2
	3/8	6.4	76	146	132.5	80	2
	1/2	12.7	86	157	140	80	2.5
	3/4	17.5	102	194	173	110	3.5
	1	23.8	118	239	209	150	7
	1 1/4	28.6	118	263	228	150	7
	1 1/2	36.5	132	290	247	150	10.5
	2	44.5	178	328	270	180	15
1500	1/4	6.4	76	214	198	80	4
	3/8	6.4	76	214	198	80	4
	1/2	12.7	86	218	202	80	4.5
	3/4	15.9	102	239	218	110	6.5
	1	22.2	127	275	245	150	9.5
	1 1/4	27	152	290	255	150	11
	1 1/2	34.9	171	313	272	150	14.5
	2	38.1	210	365	317	180	20

FORGED STEEL GLOBE VALVES

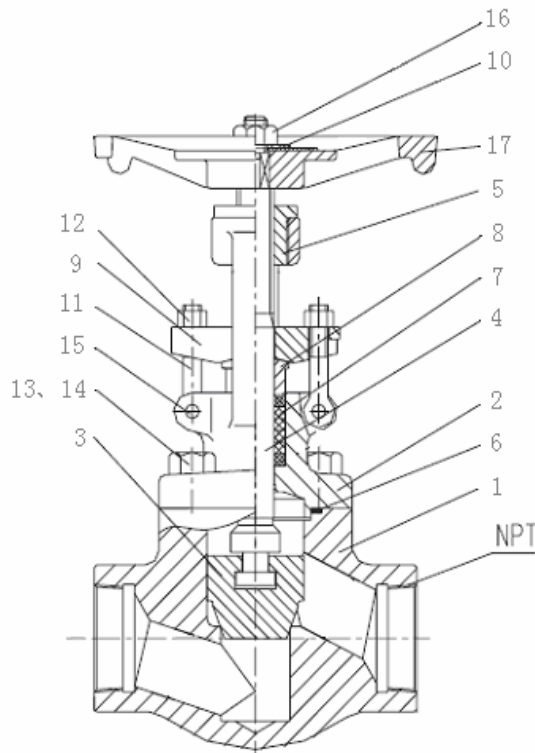

Technical Data

Pressure Ratings: Class800~Class2500

Shell Wall Thickness: API 602

End Threads: ASME B 1.20.1

Socket-weld: ASME B 16.11

Test and Inspection: API 598

Material Specifications

No.	Parts	Materials
		ASTM
1	Body	A105①
2	Bonnet	A105
3	Disc	A182 F6a①
4	Stem	A182 F6a
5	Stem Nut	A439 D2 / Bronze
6	Gasket	304 SS
7	Packing	304 + Flexible Graphite
8	Gland	A276 420
9	Glande Flange	CS
10	Washer	CS
11	Eyebolt	A193 B7
12	Nut	A194 2H
13	Bolt	A193 B7
14	Nut	A194 2H
15	Pin	CS
16	Handwheel Nut	CS
17	Handwheel	Cast Iron

Note: ① Seal surface materials can be designed according to customer's requirement.

ANSI FORGED STEEL GLOBE VALVES

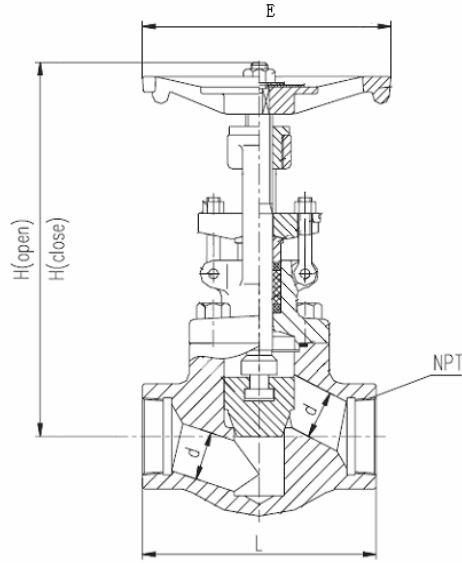

Dimensions and Weights (Class800~Class2500)

Class	NPS(in)	Dimensions(mm)				Weights(kg)	
		d	L	H			E
				Open	Close		
800	1/4	6.4	76	146	135	80	2
	3/8	6.4	76	146	135	80	2
	1/2	9.5	76	146	135	80	2
	3/4	12.7	86	154	142	80	2.5
	1	17.5	102	195	183	110	3.5
	1 1/4	23.8	140	195	183	150	8
	1 1/2	28.6	140	231	214	150	8
1500	2	36.5	170	277	254	150	11.5
	1/4	6.4	76	211	195	100	4
	3/8	6.4	76	211	195	100	4
	1/2	9.5	76	211	195	100	4
	3/4	12.7	86	218	200	100	4.5
	1	15.9	111	243	220	125	6.5
	1 1/4	22.2	152	277	248	160	9
2500	1 1/2	27	152	290	255	160	12
	2	34.9	171	316	275	180	18.5
	1/2	9.5	127	176	148	130	7
	3/4	12.7	155	242	218	130	9
	1	15.9	170	257	230	130	14.5
2500	1 1/2	27	235	429	385	180	34
	2	34.9	235	434	392	225	37

FORGED STEEL LIFT CHECK VALVES

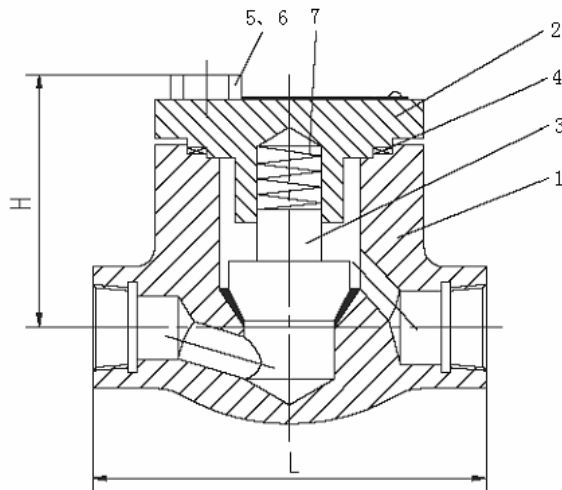

Technical Data

Pressure Ratings: Class800~Class1500
 Shell Wall Thickness: API 602
 End Threads: ASME B 1.20.1
 Socket-weld: ASME B 16.11
 Test and Inspection: API 598

Material Specifications

NO.	Parts	Materials
		ASTM
1	Body	A105①
2	Bonnet	A105
3	Disc	A182 F6a①
4	Gasket	304SS
5	Bolt	A193 B7
6	Nut	A194 2H
7	Spring	SS

Note: ①Seal surface materials can be designed according to customer's requirement.

Dimensions and Weights (Class800 ~ Class1500)

Class		800							
NPS(in)		1/4	3/8	1/2	3/4	1	1 1/4	1 1/2	2
Dimensions (mm)	L	79	79	79	92	120	152	152	172
	H	51	51	51	55	69	103	103	118
Weights (kg)		1.5	1.5	1.5	2	2.5	5.5	5.5	9
Class		1500							
NPS(in)		1/4	3/8	1/2	3/4	1	1 1/4	1 1/2	2
Dimensions (mm)	L	79	79	79	92	120	152	152	172
	H	51	51	51	55	69	103	103	118
Weights (kg)		2	2	2	2.5	4	8	8	13